

## CSMU-002 Soda ash mixing unit user manual

### General Description:

---

Caustic soda is used to maintain or increase pH, Avoid exposure and handle only when fully protected. Care should be taken when mixing. Caustic soda should be added slowly to the mud system through a properly designed chemical mixing unit. Do not mix caustic soda with other chemicals or through the mud hopper. When using the chemical barrel, fill to the desired level with water, then add dry caustic soda

#### Product Features

Enclosed Design:Features an enclosed sack cutting closet and dust containment hood to isolate chemical powder during loading.



Pneumatic Operation:Powered by an air motor, eliminating electrical sparks and flare risks for safe operation in hazardous environments.The rotational speed will increase as the air intake increases.



Efficient Mixing:A conical induction mixer (propeller) ensures a full and vortex mixing action.



Safety & Monitoring: Includes an integrated a Teflon viewing window, and an overflow bypass.

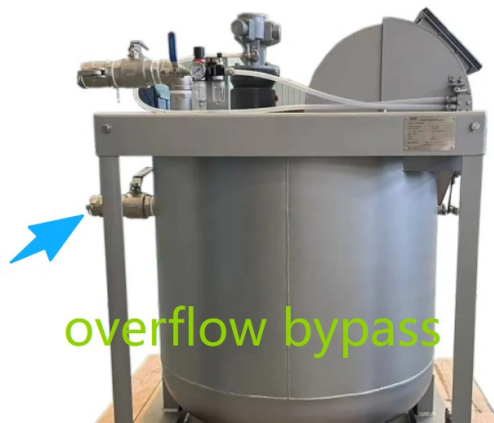

Durable Construction: Built from corrosion-resistant Stainless Steel 304.

Integrated Skid: For easy transport and placement on the rig.

### Installation Considerations:

---

The Mixing Tank is shipped fully assembled. Selection of the installation site should be based upon the following:

- Structurally sound installation site to support the weight of the tank when full.
- Access to water and air.
- Controlled discharge into the mud system.
- Access to the mixing tank access door for adding chemicals to the mixing tank.

### Operating Procedure:

---



**DANGER:** This unit is designed for mixing hazardous chemicals, such as caustic soda.

Chemicals can cause severe injury. Always avoid exposure and handle only when fully protected with appropriate Personal Protective Equipment (PPE) as specified by the chemical's Material Safety Data Sheet (MSDS).

- Follow all recommended safety procedures listed on the MSDS of any chemical handled.
- All personnel should be supplied with proper HSE PPE for the handling of any chemical
- The installation of the mixing tank should be checked that the equipment is level and secured so that the tank will not move or tip over.
- To connect the overflow discharge hose to the 2" camlock fitting, and put the discharge hose safely into the mud system in case of spill to the floor.



- connect the fluids discharge hose to the mud pit which you intend to add to .use the ball valve to control the operation.



- With the mixing tank empty, add the required product to the tank. Consult the mud engineer for the required quantity of the product to be mixed with 100 gallons of water. Insert the sack of product through the access door and shut the door. Use the sack cutter to empty the product into the mixing tank.

**WARNING: ALWAYS add chemical slowly to water. NEVER add water to dry chemical. NEVER operate the mixer without water in the tank.**

- With the access door shut, add water to the mixing tank through the 2" water inlet. Fill the tank  $\frac{1}{2}$  way up and turn on the air to the air motor. The access door has a safety air shuttle valve, when the lid is open, the air will be shut down by the valve, so the agitator will never rotate by mistake, and while the lid be closed, the air will be engaged automatically.



- filling the tank and make sure water level is below the overflow pipe.
- Mix the solution per the product MSDS until the solution is properly mixed.
- Turn off the Air Motor before discharging the solution from the SAFECEM Mixing Tank.
- Open the 2" ball valve to discharge the solution.
- Once the tank is drained the access door can be opened. Excess product left behind in the tank should be cleaned after each use.

### Maintenance Procedure:

---

#### 1.0 Introduction

This manual provides maintenance procedures for the CSMU-002 Soda Ash Mixing Unit. Proper maintenance is critical for ensuring safe operation, especially when handling hazardous chemicals like caustic soda. Adherence to these procedures will extend equipment life and prevent accidents.

#### 2.0 Safety Precautions

**PERSONAL PROTECTIVE EQUIPMENT (PPE):** Always wear appropriate PPE as specified by the chemical's Material Safety Data Sheet (MSDS) before performing any maintenance.

**LOCKOUT/TAGOUT:** Ensure the air supply is disconnected and locked out before starting any maintenance tasks.

**HAZARDOUS RESIDUES:** Be aware that the unit may contain hazardous chemical residues. Clean thoroughly before inspection or servicing.

#### 3.0 Post-Use Maintenance (After Each Operation)

##### 3.1 Tank Cleaning

**Purpose:** To eliminate the build-up of un-mixed product in the bottom of the tank and the discharge pipe, which can cause blockages or improper mixing.

**Procedure:**

After discharging the mixed solution, open the access door.

Thoroughly rinse the tank interior and the discharge pipe with clean water.

Remove any excess product left behind in the tank.

Allow the tank to dry or drain completely.

#### 4.0 Routine Maintenance

##### 4.1 Air Motor Lubrication

**Frequency:** Regularly, as part of a scheduled maintenance program. Check the oil level before daily operation.

**Procedure:**

Locate the lubricating oil cup beside the air regulator.

Fill the oil cup with the recommended lubricant for air motors.

## Recommended Brands and Products not limited to

### Selection Criteria

Viscosity Grade: ISO VG 32 (recommended by equipment manufacturer)

Oil Type: Air tool oil or pneumatic tool oil

Key Properties: Good anti-wear performance, anti-rust and anti-corrosion protection, suitable for low-temperature environments (-10°C)

Brand	Product Name	Viscosity Grade	Type
Shell	Shell Air Tool S2 A32	ISO VG 32	Air Tool Oil
Mobil	Mobil DTE 24 UT	ISO VG 32	Hydraulic Oil
Total	Total PNEUMA NA 32	ISO VG 32	Air Tool Oil
Chevron	Chevron Pneumatic Tool Oil	ISO VG 32	Air Tool Oil
Ingersoll Rand	Ingersoll Rand Air Tool Oil	ISO VG 32	Air Tool Oil

Maintain the oil level to ensure smooth operation and prevent motor wear.

### 4.2 Inspection of Safety Air Shuttle Valve

Frequency: Weekly or before each use.

Purpose: To ensure the safety feature that prevents agitator operation when the access door is open is functional.

Procedure:

With the air supply connected, open the access door. The air motor should not start.

Close the access door. The air supply should engage, and the motor can be started normally.

If the valve does not function correctly, do not operate the unit and schedule repair.

### 4.3 General Visual Inspection

Frequency: Weekly.

Procedure:

Inspect the tank, hoses, and fittings for signs of corrosion, leaks, or damage.

Check that all connections (air, water, discharge hoses) are secure.

Verify the unit is level and secured to prevent movement or tipping.

## 5.0 Component-Specific Care

### 5.1 Sack Cutter (Sack Slitter)

**WARNING:** The sack slitter has a very sharp knife.

Handling:

Always push the knife handle all the way in before inserting the bag to avoid cutting your fingers. Inspect the blade for dullness or damage. Replace if necessary.

### 5.2 Teflon Viewing Window

**Cleaning:** Clean with a soft cloth and a compatible cleaner to maintain visibility.

**Inspection:** Check for cracks or severe scratching that could compromise containment.

## 6.0 Maintenance Log

Date	Maintenance Performed	Maintenance Performed	Maintenance Performed
	Post-Use Cleaning Air Motor Lubrication Safety Valve Check Visual Inspection Component Inspection		



**Watch out! The sack slitter has very sharp knife, Always push the knife handle all the way in before inserting the bag to avoid cutting your fingers.**

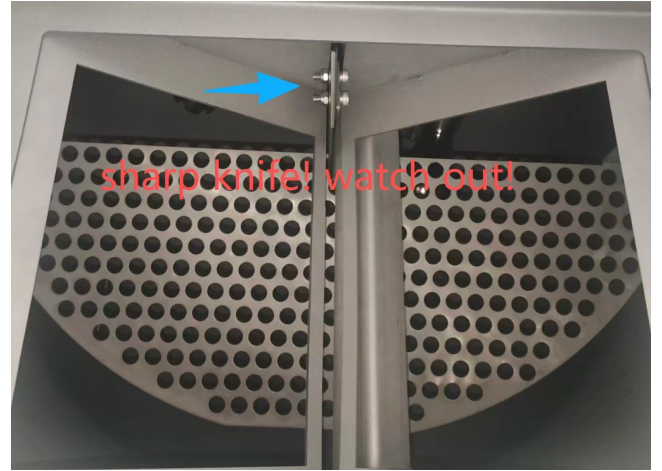

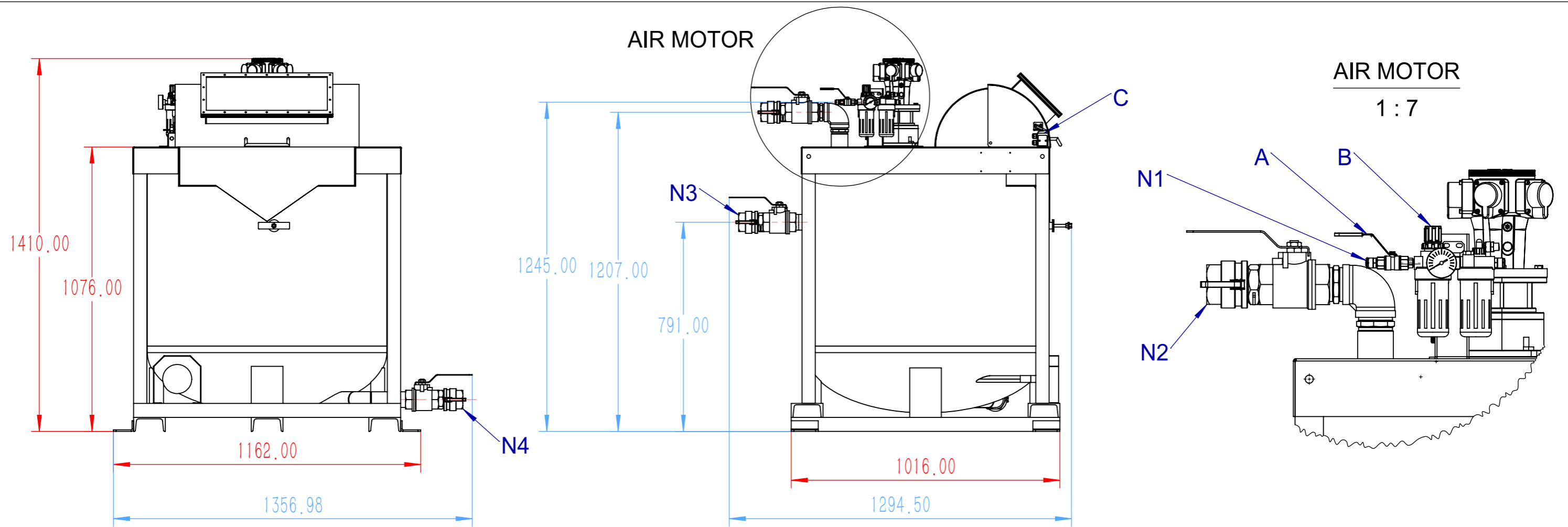

CODE	NAME	DESCRIPTION	REMARK
C	SAFTEY AIR VALVE		1/4" INTERAL FITTING
B	MOTOR		1/4" INTERAL FITTING
A	BALL VALVE		1/4" INTERAL FITTING
N1	AIR INLET	2" BALL VALVE + 2" DF CAMLOCK	ID8mm/OD12mm AIR HOSE
N2	WATER INLET	2" BALL VALVE + 2" DF CAMLOCK	2" PT THREAD
N3	OVERFLOW	2" BALL VALVE + 2" DF CAMLOCK	2" PT THREAD
N4	FLUID OUTLET	2" BALL VALVE + 2"DF CAMLOCK	2" PT THREAD

<b>PRM</b>		Premium ( LiaoNing ) Oilfield Technology Co.,Ltd		P/N	
WEIGHT(kg):238		material:304ss	SCALE : 1:15	DWG No.	
DIMENSIONS(mm) : 1410x1357x1294.5mm			QTY : 1		
DESCRIPTION :			PROCESSING METHOD	DevName	CSMU-002
			SHEET : 1/2		
			VERSION : 1	Part name	CSMU-002
		DATE	CHANGE :		

20	SEALS-2	2	EA	P-CSMU-019	499x221x3mm
19	SEALS-1	1	EA	P-CSMU-018	902x757.9x3mm
18	ELBOW INNER THREAD	1	EA	P-CSMU-002	2" , AISI304
17	FITTING OUTER THREAD	2	EA	P-CSMU-003	2" , AISI304
16	AIR SHUTTLE VALVE	1	EA	P-CSMU-017	S3R-08
15	CUTTING BLADE	1	EA	P-CSMU-013	70x40x1.2mm ,HSS
14	INSPECTION WINDOW	1	EA	P-CSMU-017	499x221x6mm
13	THERMAL GUAGE	1	EA	P-CSMU-006	M20x1.5 THREAD,AISI304
12	BALL VALVE FOR AIR HOSE	1	EA	P-CSMU-008	1/4" , AISI304
11	FITTING	1	EA	P-CSMU-009	1/4" , AISI304
10	D+F STYLE CAMPLOCK	3	SET	P-CSMU-004	2" , AISI304
9	BALL VALVE	3	EA	P-CSMU-001	2" , AISI304
8	AIR HOSE QUICK FITTING	5	EA	P-CSMU-007	1/4"(ZG1/4-12x8) , AISI304
7	BFC2000 AIR REGULAR	1	EA	P-CSMU-011	1/4"
6	AIR MOTOR	1	EA	P-CSMU-005	1/4" INLET , HXHM4G5180
5	HAMMER-TYPE STIRRING PADDLE	1	EA	P-CSMU-016	
4	MIXING SHAFT	1	EA	P-CSMU-015	
3	SHAFT COUPLING	1	EA	P-CSMU-014	
2	MIXING TANK	1	EA		
1	MIXING TANK LID	1	EA		
<b>ITEM</b>	<b>PART NAME</b>	<b>QTY</b>	<b>UNIT</b>	<b>PART NUMBER</b>	<b>DESCRIPTION</b>

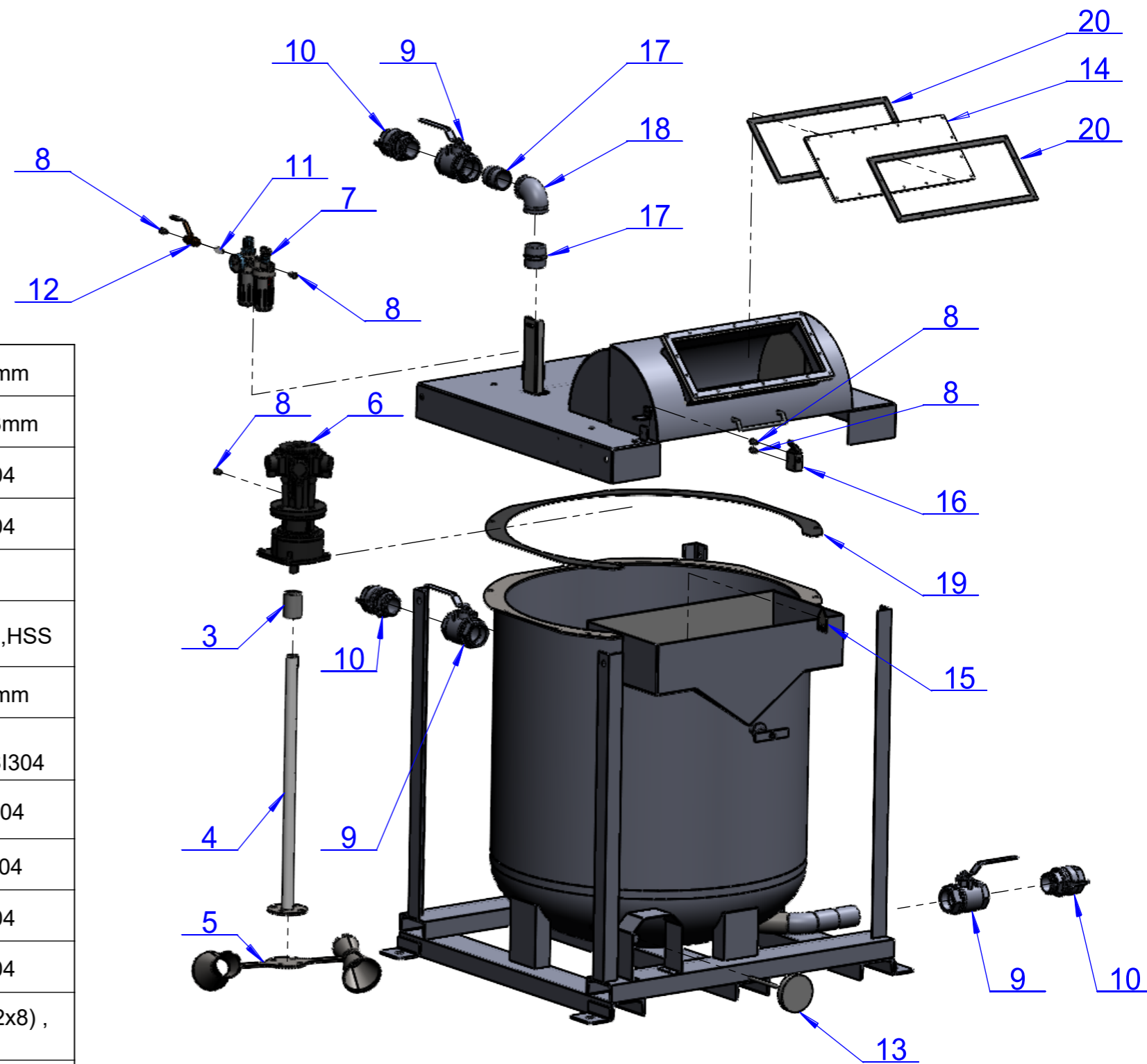

<b>PRM</b>	Premium ( LiaoNing ) Oilfield Technology Co.,Ltd		P/N	
	WEIGHT(kg):238	SCALE : 1:15	DWG No.	
DIMENSIONS(mm) : 1410x1357x1294.5mm		QTY : 1	PROCESSING METHOD	
DESCRIPTION :			DevName	CSMU-002
		SHEET : 2/2	Part name	CSMU-002
		VERSION : 1		
	DATE	CHANGE :		